

BT Shank

Tipo 1

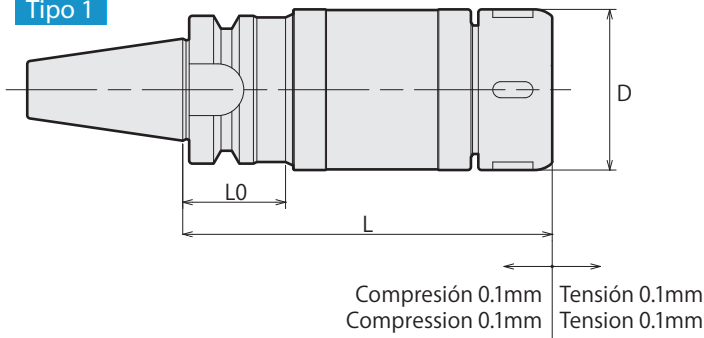

Tipo 2

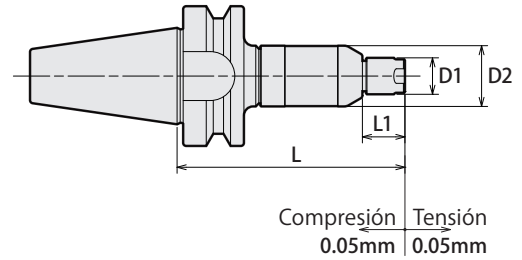
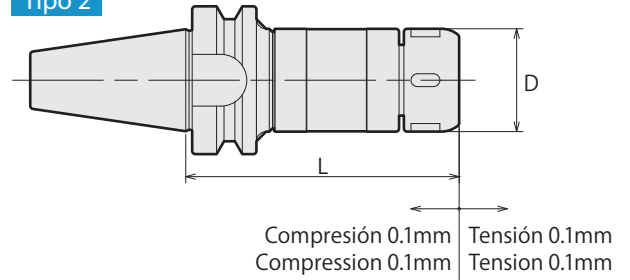

Código Code	Modelo Model	L	L1	D1	D2	kg
2450 00108075	BT30 -SMH 8 - 75	75	14	12	20	0.5
2450 00308080	BT40 -SMH 8 - 80	80	14	12	20	1.1

Código Code	Modelo Model	Type	L	L0	D	kg		
2450 00116090	BT30 -SMH16 - 90	2	90	-	32	0.7		
2450 00116120			-120	2	120	-	32	0.9
2450 00132120	-SMH32 -120	1	120	37	50	1.4		
2450 00316090	BT40 -SMH16 - 90	2	90	-	32	1.2		
2450 00316120			-120	2	120	-	32	1.4
2450 00332120	-SMH32 -120	2	120	-	50	1.9		
2450 00516105	BT50 -SMH16 -105	2	105	-	32	3.8		
2450 00516150			-150	2	150	-	32	4.1
2450 00532125	-SMH32 -125	2	125	-	50	4.4		

Accesorios - Accessories				
Medida Holder Size	Medida de machuelo Tap Size	Boquilla Collet	Tuerca ciega Nut	Llave inglesa Spanner
SMH16	M3~M12 U no.5~U1/2 PT1/16 · PT1/8	ER16GH	ERP-16T	FKT-32L
SMH32	M10~M20 U3/8~U13/16 PT1/16~PT3/8	ER32GH	ERP-32T	FKT-50L

1. La llave inglesa y la boquilla se venden por separado.
2. Para seleccionar la medida correcta del machuelo, revise la tabla de medidas.
3. Utilice los productos con una maquina que tenga función sincrónica.

1. Collet and spanner are sold separately.
2. For the corresponding tap size, refer to the tap collet dimension page.
3. Please use with a machine with synchronous function.

Ejemplo para ordenar - Ordering Example

BT30 - SMH16 - 90

Interfaz y diámetro de husillo Medida de portaherramienta Longitud de proyección
Shank size Holder size Projection length

ST Shank

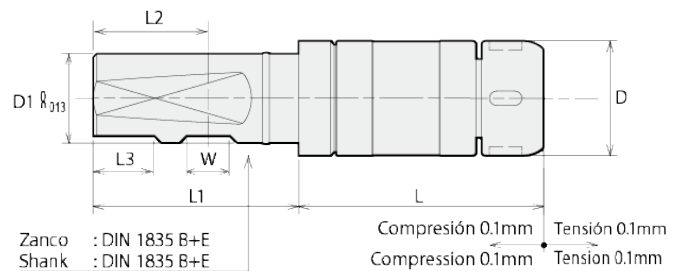
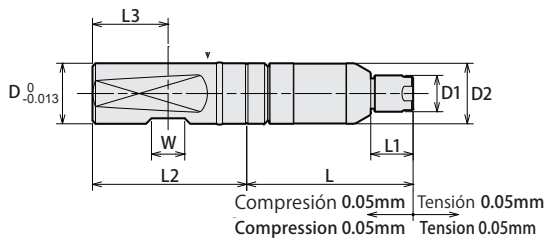

Código Code	Modelo Model	L	L1	L2	L3	D	D1	D2	W	kg
0440 02008055	ST20D -SMH 8 -55	55	14	51	25	20	12	20	11	0.2

Código Code	Modelo Model	L	L1	L2	L3	D	D1	W	kg
0440 02016068	ST20D -SMH16 -68	68	51	25	—	32	20	11	0.4
0440 02516068	ST25D -SMH16 -68	68	57	32	17	32	25	12	0.5

Accesorios - Accessories				
Medida Holder Size	Medida de machuelo Tap Size	Boquilla Collet	Tuerca ciega Nut	Llave inglesa Spanner
SMH16	M3~M12 U no.5~U1/2 PT1/16 · PT1/8	ER16GH	ERP-16T	FKT-32L

1. La llave inglesa y la boquilla se venden por separado.
2. Para seleccionar la medida correcta del machuelo, revise la tabla de medidas.
3. Utilice los productos con una maquina que tenga función sincrónica.

1. Collet and spanner are sold separately.
2. For the corresponding tap size, refer to the tap collet dimension page.
3. Please use with a machine with synchronous function.

Ejemplo para ordenar - Ordering Example

BT30 - SMH16 - 90

Interfaz y diámetro de husillo Medida de portaherramienta Longitud de proyección
Shank size Holder size Projection length