

PHC-A

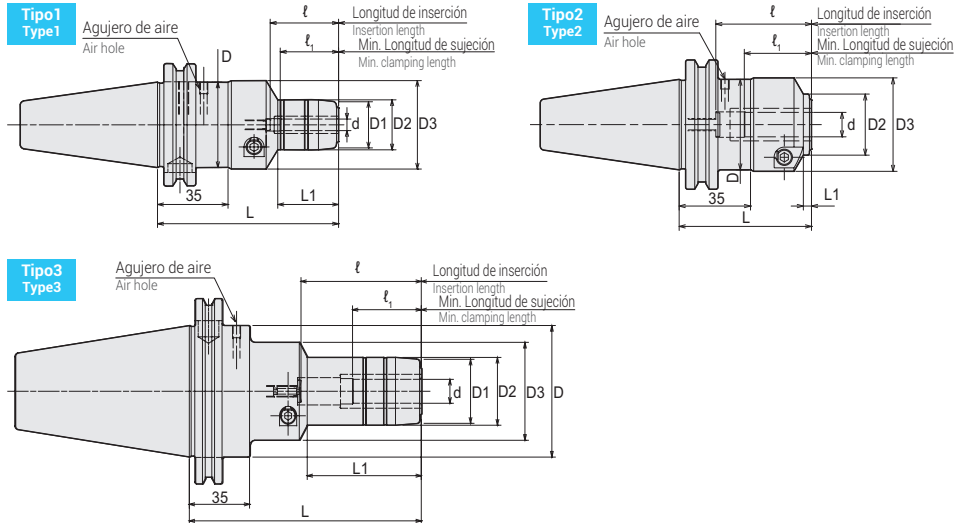

Power Hydro Chuck

- Hydro Chuck con capacidad de uso de boquillas. Adecuado para cortes de alta precisión.
- Hydro chuck with collet holder flexibility. Suitable for high precision cutting.



Medida en Pulgadas - Inch Sizes

Unidad : Pulgadas
Unit : Inch

Código Code	Modelo Model	Tipo Type	d	L	L ₁	D	D ₁	D ₂	D ₃	ℓ	ℓ ₁	Llave Allen (Opcional) Hex. Wrench (Optional)
393200674000	CAT40 -PHC0125A - 75	1	0.125	2.953	0.78	1.75	—	0.945	1.791	1.102	0.709	L-4T (4mm)
1860 11408065	CAT40 -PHC0250A - 65	2	0.25	2.56	0.158	1.75	—	1.024	1.807	1.338	1.142	
1860 11408090	- 90	1	0.25	3.544	1.19	1.75	0.945	1.024	1.811	1.338	1.142	
1860 11408120	- 120	1	0.25	4.725	1.623	1.75	0.945	1.024	1.811	1.771	1.142	
1860 11410065	CAT40 -PHC0312A - 65	2	0.312	2.56	0.158	1.75	—	1.103	1.807	1.338	1.142	
1860 11410090	- 90	1	0.312	3.544	1.213	1.75	1.024	1.103	1.811	1.338	1.142	
1860 11410120	- 120	1	0.312	4.725	1.646	1.75	1.024	1.103	1.811	1.771	1.142	
1860 11412065	CAT40 -PHC0375A - 65	2	0.375	2.56	0.158	1.75	—	1.182	1.807	1.771	1.3	
1860 11412105	- 105	1	0.375	4.134	1.758	1.75	1.103	1.182	2.048	1.968	1.575	
1860 11412135	- 135	1	0.375	5.315	2.546	1.75	1.103	1.182	2.048	2.755	1.575	
1860 11416065	CAT40 -PHC0500A - 65*	2	0.5	2.56	0.158	1.75	—	1.182	1.969	1.771	1.3	
1860 11416105	- 105*	1	0.5	4.134	1.826	1.75	1.339	1.418	2.048	1.968	1.575	
1860 11416135	- 135*	1	0.5	5.315	2.614	1.75	1.339	1.418	2.048	2.755	1.575	
1860 11420065	CAT40 -PHC0625A - 65	2	0.625	2.56	0.158	1.75	—	1.182	1.969	17.71	1.3	
1860 11420105	- 105	1	0.625	4.134	1.849	1.75	1.418	1.496	2.048	1.968	1.575	
1860 11420135	- 135	1	0.625	5.315	2.637	1.75	1.418	1.496	2.048	2.755	1.575	
1860 11424105	CAT40 -PHC0750A - 105*	1	0.75	4.134	1.963	1.75	1.575	1.654	1.811	1.968	1.575	
1860 11424135	- 135*	1	0.75	5.315	2.75	1.75	1.575	1.654	1.811	2.755	1.575	
1860 11432120	CAT40 -PHC1000A - 120	1	1	4.725	2.328	1.75	1.969	2.048	2.441	2.362	1.969	L-6T (6mm)
1860 11432150	- 150	1	1	5.906	3.115	1.75	1.969	2.048	2.441	3.149	1.969	
1860 11440135	CAT40 -PHC1250A - 135	1	1.25	5.315	—	1.75	2.363	2.441	2.441	2.952	2.56	
1860 11440165	- 165	1	1.25	6.496	—	1.75	2.363	2.441	—	3.149	2.56	

Medida en Pulgadas - Inch Sizes

Unidad : Pulgadas
Unit : Inch

Código Code	Modelo Model	Tipo Type	d	L	L ₁	D	D ₁	D ₂	D ₃	ℓ	ℓ ₁	Llave Allen (Opcional) Hex. Wrench (Optional)
393200669000	CAT50 -PHC0250A - 90	3	0.25	3.544	1.19	2.75	0.945	1.024	1.811	1.338	1.142	
393200667000	- 120	3	0.25	4.725	1.623	2.75	0.945	1.024	1.811	1.771	1.142	
393200668000	- 150	3	0.25	5.906	1.623	2.75	0.945	1.024	1.811	1.771	1.142	
393200672000	CAT50 -PHC0312A - 90	3	0.312	3.544	1.213	2.75	1.024	1.103	1.811	1.338	1.142	
393200670000	- 120	3	0.312	4.725	1.646	2.75	1.024	1.103	1.811	1.771	1.142	
393200671000	- 150	3	0.312	5.906	1.646	2.75	1.024	1.103	1.811	1.771	1.142	
393200661000	CAT50 -PHC0375A - 105	3	0.375	4.134	1.758	2.75	1.103	1.182	2.048	1.968	1.575	
393200662000	- 135	3	0.375	5.315	2.546	2.75	1.103	1.182	2.048	2.755	1.575	
393200663000	- 165	3	0.375	6.496	2.546	2.75	1.103	1.182	2.048	2.755	1.575	
—	CAT50 -PHC0500A - 105*	3	0.5	4.134	1.826	2.75	1.339	1.418	2.048	1.968	1.575	
393200673000	- 135*	3	0.5	5.315	2.614	2.75	1.339	1.418	2.048	2.755	1.575	
393200652000	- 165*	3	0.5	6.496	2.614	2.75	1.339	1.418	2.048	2.755	1.575	
393200653000	CAT50 -PHC0625A - 105	3	0.625	4.134	1.849	2.75	1.418	1.496	2.048	1.968	1.575	
393200654000	- 135	3	0.625	5.315	2.637	2.75	1.418	1.496	2.048	2.755	1.575	
393200655000	- 165	3	0.625	6.496	2.637	2.75	1.418	1.496	2.048	2.755	1.575	
186200031000	CAT50 -PHC0750A - 105*	3	0.75	4.134	1.963	2.75	1.575	1.654	1.811	1.968	1.575	
393200656000	- 135*	3	0.75	5.315	2.75	2.75	1.575	1.654	1.811	2.755	1.575	
393200657000	- 165*	3	0.75	6.496	2.75	2.75	1.575	1.654	1.811	2.755	1.575	
393200658000	CAT50 -PHC1000A - 120	3	1	4.725	2.328	2.75	1.969	2.048	2.441	2.362	1.969	
393200659000	- 150	3	1	5.906	3.115	2.75	1.969	2.048	2.441	3.149	1.969	
393200660000	- 165	3	1	6.496	3.115	2.75	1.969	2.048	2.441	3.149	1.969	
393200675000	CAT50 -PHC1250A - 135	3	1.25	5.315	—	2.75	2.363	2.441	—	2.952	2.56	L-6T (6mm)
393200664000	- 165	3	1.25	6.496	—	2.75	2.363	2.441	—	3.149	2.56	

1. Favor de utilizar herramientas de corte con una tolerancia menor a h7. Es recomendada una tolerancia menor que 0/-0.01 para nuevas herramientas de corte.
2. No dejar el portaherramienta con el tornillo de accionamiento apretado cuando el diámetro interno del portaherramienta se encuentre sin herramienta de corte.
3. PHC0500A Y PHC0750A cuentan con orificios de acople para perno, para las boquillas que tienen incluido el perno de retención.
4. El tornillo Allen es necesario para tapar el orificio de aire para habilitar la alimentación de refrigeración por centro de la boquilla.
5. * Es posible utilizar boquillas PHS.

1. Please use a cutting tool with a tolerance of less than h7. A tolerance of less than 0/-0.01 is recommended for new cutting tools.
2. Do not leave the holder with actuating screw tightened when the chuck is empty.
3. PHC0500A and PHC0750A have pin holes for collet with stopper pin on its body.
4. Hex-head screws are necessary to plug air hole for center through coolant feed.
5. * Compatible for PHS collet use.

Ejemplo para Ordenar - Ordering Example

CAT40 - PHC 0250 A - 120

Interfaz y diámetro
de husillo

Shank size

Diámetro
Interno

I.D.(d)

Longitud de
proyección

Projection length(L)

Torque recomendado (Llave Allen : Pág. 520)
Tightening torque (Torque wrench : P. 520)

Modelo Model	I.D. (d)		Torque de ajuste Tightening torque (Nm)
	Pulgada-inch	Métrico-metric	
PHC-A	0250 ~ 0312	06~08	11 ~ 12
PHC-A	0375 ~ 0750	09~20	7 ~ 8
PHC-A	1000, 1250	25, 32	29 ~ 30

Boquilla PHS

PHS Collet

Pág.114

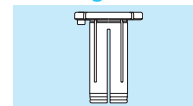

Llave Allen

Hex. wrench

Pág. 099



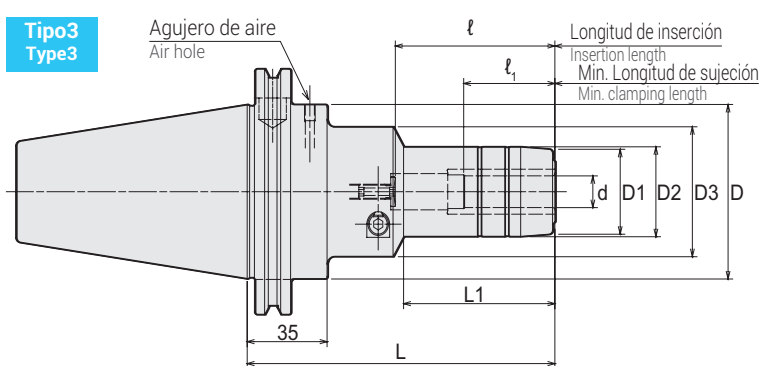
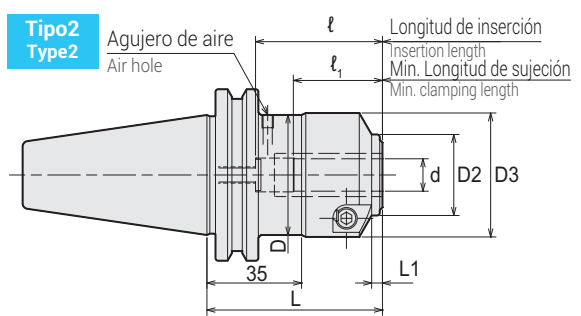
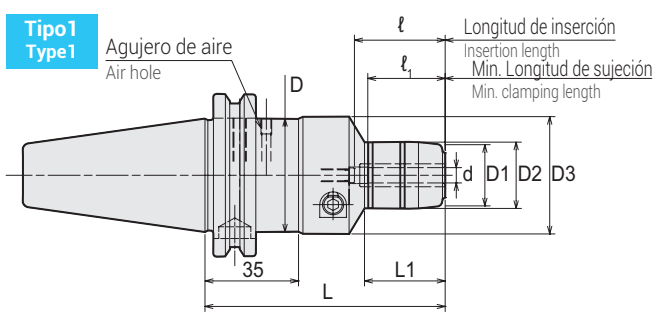

Medidas Métricas - Metric Sizes Unidad : Métrico
Unit : Metric

Código Code	Modelo Model	Tipo Type	d	L	L ₁	D	D ₁	D ₂	D ₃	ℓ	ℓ ₁	Llave Allen (Opcional) Hex. Wrench (Optional)
1860 01403075	CAT40 -PHC03A - 75	1	3	75	19.8	—	24	46	—	—	18	L-4T (4mm)
1860 01404080	CAT40 -PHC04A - 80	1	4	80	25.1	—	25	46	—	29	24	
1860 01406065	CAT40 -PHC06A - 65	2	6	65	4	—	—	26	44.45	34	29	
1860 01406090	- 90	1	6	90	30	44.45	24	26	46	34	29	
1860 01406120	- 120	1	6	120	41	44.45	24	26	46	45	29	
1860 01407065	CAT40 -PHC07A - 65	2	7	65	4	—	—	28	44.45	34	29	
1860 01407090	- 90	1	7	90	30	44.45	26	28	46	34	29	
1860 01407120	- 120	1	7	120	41	44.45	26	28	46	45	29	
1860 01408065	CAT40 -PHC08A - 65	2	8	65	4	—	—	28	44.45	34	29	
1860 01408090	- 90	1	8	90	30	44.45	26	28	46	34	29	
1860 01408120	- 120	1	8	120	41	44.45	26	28	46	45	29	
1860 01409065	CAT40 -PHC09A - 65	2	9	65	4	—	—	30	44.45	45	33	
1860 01409105	- 105	1	9	105	44	44.45	28	30	52	50	40	
1860 01409135	- 135	1	9	135	64	44.45	28	30	52	70	40	
1860 01410065	CAT40 -PHC10A - 65	2	10	65	4	—	—	30	44.45	45	33	
1860 01410105	- 105	1	10	105	44	44.45	28	30	52	50	40	
1860 01410135	- 135	1	10	135	64	44.45	28	30	52	70	40	
1860 01411065	CAT40 -PHC11A - 65	2	11	65	4	—	—	30	44.45	45	33	
1860 01411105	- 105	1	11	105	45	44.45	30	32	52	50	40	
1860 01411135	- 135	1	11	135	65	44.45	30	32	52	70	40	
1860 01412065	CAT40 -PHC12A - 65 *	2	12	65	4	—	—	30	44.45	45	33	
1860 01412105	- 105 *	1	12	105	45	44.45	30	32	52	50	40	
1860 01412135	- 135 *	1	12	135	65	44.45	30	32	52	70	40	
1860 01413065	CAT40 -PHC13A - 65	3	13	65	4	44.45	—	30	50	45	33	
1860 01413105	- 105	1	13	105	46	44.45	34	36	52	50	40	
1860 01413135	- 135	1	13	135	66	44.45	34	36	52	70	40	
1860 01414065	CAT40 -PHC14A - 65	3	14	65	4	44.45	—	30	50	45	33	
1860 01414105	- 105	1	14	105	46	44.45	34	36	52	50	40	
1860 01414135	- 135	1	14	135	66	44.45	34	36	52	70	40	
1860 01415065	CAT40 -PHC15A - 65	3	15	65	4	44.45	—	30	50	45	33	
1860 01415105	- 105	1	15	105	46	44.45	36	38	52	50	40	
1860 01415135	- 135	1	15	135	66	44.45	36	38	52	70	40	
1860 01416065	CAT40 -PHC16A - 65	3	16	65	4	44.45	—	30	50	45	33	
1860 01416105	- 105	1	16	105	46	44.45	36	38	52	50	40	
1860 01416135	- 135	1	16	135	66	44.45	36	38	52	70	40	
1860 01420105	CAT40 -PHC20A - 105 *	1	20	105	49	44.45	40	42	46	50	40	
1860 01420135	- 135 *	1	20	135	69	44.45	40	42	46	70	40	
1860 01425120	CAT40 -PHC25A - 120	1	25	120	59	44.45	50	52	62	60	50	
1860 01425150	- 150	1	25	150	79	44.45	50	52	62	80	50	
1860 01432135	CAT40 -PHC32A - 135	1	32	135	100	44.45	60	62	—	75	65	
1860 01432165	- 165	1	32	165	130	44.45	60	62	—	80	65	

Medidas Métricas - Metric Sizes

Unidad : Métrico
Unit : Metric

Código Code	Modelo Model	Tipo Type	d	L	L ₁	D	D ₁	D ₂	D ₃	ℓ	ℓ1	Llave Allen (Opcional) Hex. Wrench (Optional)
393200719000	CAT50 -PHC06A - 90	3	6	90	30	69.85	24	26	46	34	29	L-4T (4mm)
393200587000	- 120	3	6	120	41	69.85	24	26	46	45	29	
393200718000	- 150	3	6	150	41	69.85	24	26	46	45	29	
393200722000	CAT50 -PHC07A - 90	3	7	90	30	69.85	26	28	46	34	29	
393200720000	- 120	3	7	120	41	69.85	26	28	46	45	29	
393200721000	- 150	3	7	150	41	69.85	26	28	46	45	29	
393200650000	CAT50 -PHC08A - 90	3	8	90	30	69.85	26	28	46	34	29	
393200723000	- 120	3	8	120	41	69.85	26	28	46	45	29	
393200724000	- 150	3	8	150	41	69.85	26	28	46	45	29	
393200725000	CAT50 -PHC09A - 105	3	9	105	44	69.85	28	30	52	50	40	
303200726000	- 135	3	9	135	64	69.85	28	30	52	70	40	
393200727000	- 165	3	9	165	64	69.85	28	30	52	70	40	
393200728000	CAT50 -PHC10A - 105	3	10	105	44	69.85	28	30	52	50	40	
393200588000	- 135	3	10	135	64	69.85	28	30	52	70	40	
393200729000	- 165	3	10	165	64	69.85	28	30	52	70	40	
393200730000	CAT50 -PHC11A - 105	3	11	105	45	69.85	30	32	52	50	40	
393200731000	- 135	3	11	135	65	69.85	30	32	52	70	40	
393200732000	- 165	3	11	165	65	69.85	30	32	52	70	40	
393200733000	CAT50 -PHC12A - 105*	3	12	105	45	69.85	30	32	52	50	40	
393200589000	- 135*	3	12	135	65	69.85	30	32	52	70	40	
393200734000	- 165*	3	12	165	65	69.85	30	32	52	70	40	
393200735000	CAT50 -PHC13A - 105	3	13	105	46	69.85	34	36	52	50	40	
393200736000	- 135	3	13	135	66	69.85	34	36	52	70	40	
393200737000	- 165	3	13	165	66	69.85	34	36	52	70	40	
393200738000	CAT50 -PHC14A - 105	3	14	105	46	69.85	34	36	52	50	40	
393200739000	- 135	3	14	135	66	69.85	34	36	52	70	40	
393200740000	- 165	3	14	165	66	69.85	34	36	52	70	40	
393200741000	CAT50 -PHC15A - 105	3	15	105	46	69.85	36	38	52	50	40	
393200742000	- 135	3	15	135	66	69.85	36	38	52	70	40	
393200743000	- 165	3	15	165	66	69.85	36	38	52	70	40	
—	CAT50 -PHC16A - 105	3	16	105	46	69.85	36	38	52	50	40	
—	- 135	3	16	135	66	69.85	36	38	52	70	40	
—	- 165	3	16	165	66	69.85	36	38	52	70	40	
186200022000	CAT50 -PHC20A - 105*	3	20	105	49	69.85	40	42	46	50	40	
—	- 135*	3	20	135	69	69.85	40	42	46	70	40	
186200027000	- 165*	3	20	165	69	69.85	40	42	46	70	40	
186200023000	CAT50 -PHC25A - 120	3	25	120	59	69.85	50	52	62	64	50	
—	- 150	3	25	150	79	69.85	50	52	62	80	50	
—	- 165	3	25	165	79	69.85	50	52	62	80	50	
—	CAT50 -PHC32A - 135	3	32	135	—	69.85	60	62	—	75	65	
—	- 165	3	32	165	—	69.85	60	62	—	80	65	

1. Utilice la herramienta de corte con una tolerancia menor a h7.

Es recomendada una tolerancia menor que 0/-0.01 para nuevas herramientas de corte.

2. No dejar el portaherramienta con el tornillo de accionamiento apretado, cuando el diámetro interno del portaherramienta se encuentre sin herramienta de corte.

3. PHC12A y PHC20A cuentan con orificios de acople para perno, para las boquillas que tienen incluido el perno de retención.

4. El tornillo Allen es necesario para tapar el orificio de aire para habilitar la alimentación de refrigeración por centro de la boquilla.

5. * Es posible utilizar boquillas PHS.

1. Please use a cutting tool with a tolerance of less than h7. A tolerance of less than 0/-0.01 is recommended for new cutting tools.

2. Do not leave the holder with actuating screw tightened when the chuck is empty.

3. PHC12A and PHC20A have pin holes for collet with stopper pin on its body.

4. Hex-head screws are necessary to plug air hole for center through coolant feed.

5. * Compatible for PHS collet use.

Ejemplo para Ordenar - Ordering Example

CAT40 - PHC 09 A - 120

Interfaz y
diámetro de husillo
Shank size

Diámetro
Interno
I.D.(d)

Longitud de
proyección
Projection length(L)

Boquilla PHS
PHS Collet
Pág.114

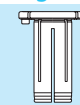

Llave Allen
Hex. wrench
Pág. 099

Torque recomendado (Llave Allen : Pág. 520)
Tightening torque (Torque wrench : P.520)

Modelo - model	I.D. (d)	Torque de ajuste Tightening torque
	mm	(Nm)
PHC-A	06 ~ 08	11 ~ 12
PHC-A	09 ~ 20	7 ~ 8
PHC-A	25, 32	29 ~ 30

Pulgada a métrico → Pulgada × 25.4
Métrico a pulgada → Métrico ÷ 25.4 ó métrico por 0.03937



Tamaños especiales / personalizados bajo pedido