

# PHC-H

## Hydro Chuck Ω

- Hydro Chuck de alta rigidez es la mejor opción para maquinados pesados (de alto impacto).
- High Rigidity Hydro Chuck is the best holder for high efficiency rough machining.

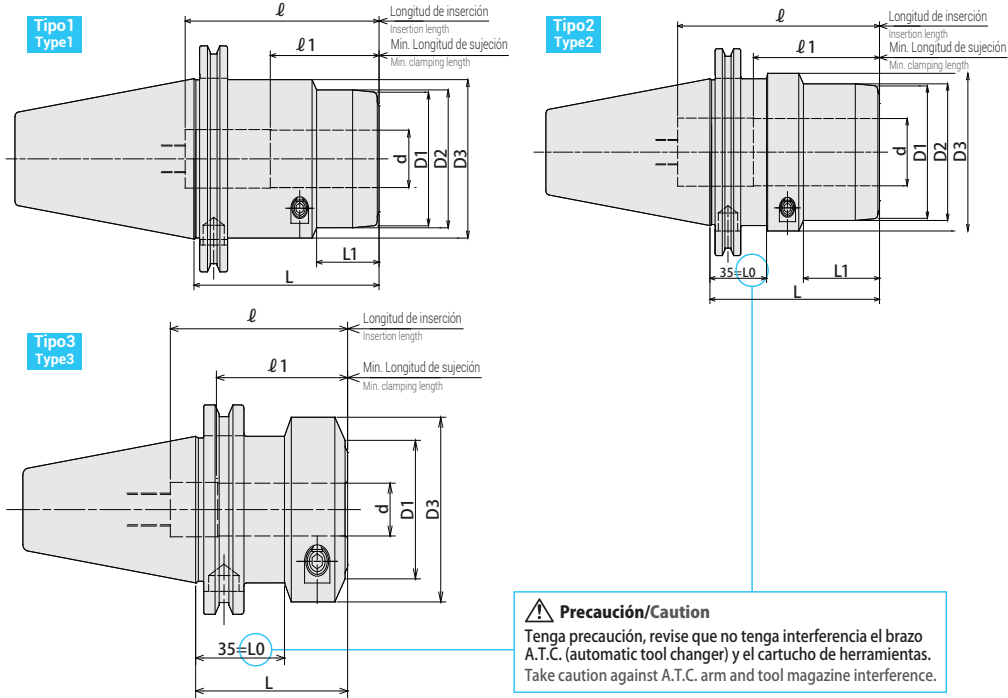

**Precaución/ Caution**  
 Tenga precaución, revise que no tenga interferencia el brazo A.T.C. (automatic tool changer) y el cartucho de herramientas.  
 Take caution against A.T.C. arm and tool magazine interference.

Código Code	Modelo Model	Tipo Type	d	L	L1	D1	D2	D3	L0	ℓ	ℓ1	Max. min <sup>-1</sup>	kg	Llave Allen (Opcional) Hex. Wrench (Optional)
182001416060	<b>CAT40 -PHC16H - 60</b>	3	16	60	—	42	—	56	35	70	45	20,000	1.2	L-4T
182001416085	- 85	2	16	85	27	42	44	56	35	85	45	20,000	1.5	
182001420085	<b>-PHC20H - 85</b>	2	20	85	26	48	50	60	35	80	50	20,000	1.6	
182001420105	- 105	2	20	105	32	48	50	60	35	110	50	20,000	2.1	L-5T
182001425085	<b>-PHC25H - 85</b>	2	25	85	25	58	60	69	35	80	55	16,000	1.8	
182001425105	- 105	2	25	105	35	58	60	69	35	110	55	16,000	2.4	
182001432120	<b>-PHC32H - 120</b>	2	32	120	47	63	65	75	35	105	65	12,000	2.4	L-5T
182001432135	- 135	2	32	135	47	63	65	75	35	120	65	12,000	3.2	
182001516085	<b>CAT50 -PHC16H - 85</b>	1	16	85	27	42	44	56	—	75	45	15,000	4.0	
182001516105	- 105	1	16	105	27	42	44	56	—	95	45	15,000	4.4	L-4T
182001520085	<b>-PHC20H - 85</b>	1	20	85	32	48	50	60	—	90	50	15,000	4.1	
182001520105	- 105	1	20	105	32	48	50	60	—	110	50	15,000	4.5	
182001525085	<b>-PHC25H - 85</b>	1	25	85	35	58	60	69	—	90	55	15,000	4.2	L-5T
182001525105	- 105	1	25	105	35	58	60	69	—	110	55	15,000	4.8	
182001525135	- 135	1	25	135	35	58	60	69	—	110	55	15,000	5.5	
182001532085	<b>-PHC32H - 85</b>	2	32	85	32	63	65	75	35	90	65	12,000	4.1	L-5T
182001532105	- 105	2	32	105	47	63	65	75	35	120	65	12,000	4.6	
182001532135	- 135	2	32	135	47	63	65	75	35	120	65	12,000	5.6	
182001542085	<b>-PHC42H - 85</b>	2	42	85	—	74	—	89	35	100	73	10,000	4.1	L-6T
182001542105	- 105	2	42	105	46	78	80	89	35	120	73	10,000	5.0	
182001542135	- 135	2	42	135	52	78	80	89	35	120	73	10,000	6.2	

### Ejemplo para Ordenar - Ordering Example

**CAT40 - PHC 16 H - 60**

Interfaz y diámetro de husillo  
Shank size

Diámetro Interior  
I.D. (d)

Longitud de Proyección  
Projection length (L)

Boquilla PHS+H  
PHS+H Collet  
Pág. 123

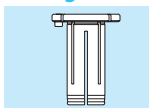

Tornillo de retención  
Stopper Bolt  
Pág. 123

